

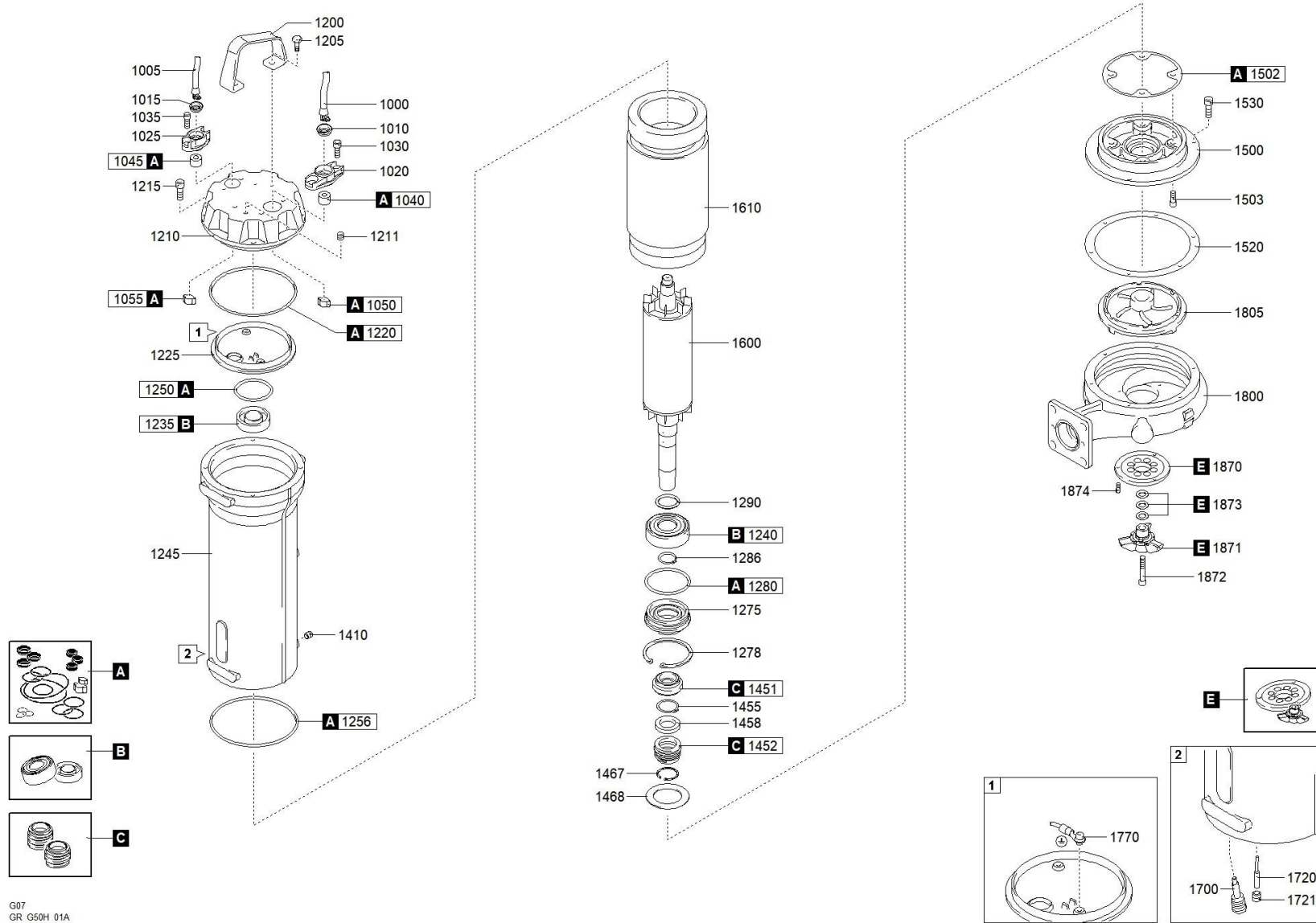

better together

1506.002 - GRG 750/2/G50H A0FT5 NGTSB51040N00NN





better together



1506.002 - GRG 750/2/G50H A0FT5 NGTSB51040N00NN

	Scanregn varenummer	Description	Antal
A	51413750A	GASKETS KIT	1
C	51413750C	MECHANICAL SEALS KIT	1
E	51413750E	CUTTING SYSTEM KIT	1
B		BEARINGS KIT	1
1000		CAVO POTENZA	1
1010		RING NUT [POWER CABLE]	1
1020		CABLE GLAND [POWER CABLE]	1
1030		SCREW - CABLE GLAND [POWER CABLE]	2
1040		RUBBER GASKET [POWER CABLE]	1
1050		COLLAR CLAMP [POWER CABLE]	1
1200		HANDLE	1
1205		SCREW [HANDLE >> COVER]	2
1210		COVER	1
1211		CAP [TIGHTNESS TEST]	1
1211		CAP [TIGHTNESS TEST]	1
1215		SCREW [COVER >> MOTOR CASE]	4
1220		GASKET [COVER >> UPPER BEARING HOLDER]	1
1225		UPPER BEARING HOLDER	1
1235	518063052Z	UPPER BEARING	1
1240	518063072ZC3	LOWER BEARING	1
1245		MOTOR CASE	1
1250		GASKET [UPPER BEARING]	1
1256		GASKET [MOTOR CASE >> PUMP PLATE]	1
1275		LOWER BEARING FLANGE	1
1278		SEEGER [LOWER BEARING FLANGE]	1
1280		GASKET [LOWER BEARING FLANGE]	1
1286		SEEGER [LOWER BEARING >> LOWER BEARING FLANGE]	1
1290		DISTANCE RING [LOWER BEARING]	1
1410		CAP [OIL CHAMBER]	1
1410		CAP [OIL CHAMBER]	1
1451		1st MECHANICAL SEAL	1
1452		2nd MECHANICAL SEAL	1
1455		SEEGER [1st MECHANICAL SEAL >> 2nd MECHANICAL SEAL]	1
1467		SEEGER [2nd MECHANICAL SEAL]	1
1468		DISTANCE RING [2nd MECHANICAL SEAL]	1
1500		PUMP PLATE	1
1502		GASKET [PUMP PLATE]	1
1503		SCREW [PUMP PLATE >> MOTOR CASE]	4

1520	5140341454	GASKET [PUMP PLATE >> PUMP BODY]	2
1530		SCREW [PUMP PLATE >> PUMP BODY]	4
1600	514137501600	SHAFT WITH ROTOR	1
1610	514137501610	WOUND STATOR	1
1700		HUMIDITY PROBE [OIL CHAMBER]	1
1800	514135501800	PUMP BODY	1
1805	514137501805	IMPELLER	1
1808		DISTANCE RING [PUMP PLATE >> IMPELLER]	1
1809		SCREW [DISTANCE RING >> PUMP PLATE]	4
1810		LOCKING IMPELLER	3
1830		SUCTION FLANGE	1
1835		GASKET [PUMP BODY >> SUCTION FLANGE]	1
1870	51413750E	CUTTING DISK	1
1871	51413750E	CHOPPER KNIFE	1
1872	51413750E	LOCKING CHOPPER KNIFE	1
1873	51413750E	WASHER [CHOPPER KNIFE]	3
1874	5140341174	SCREW [CUTTING DISK >> PUMP BODY]	3