

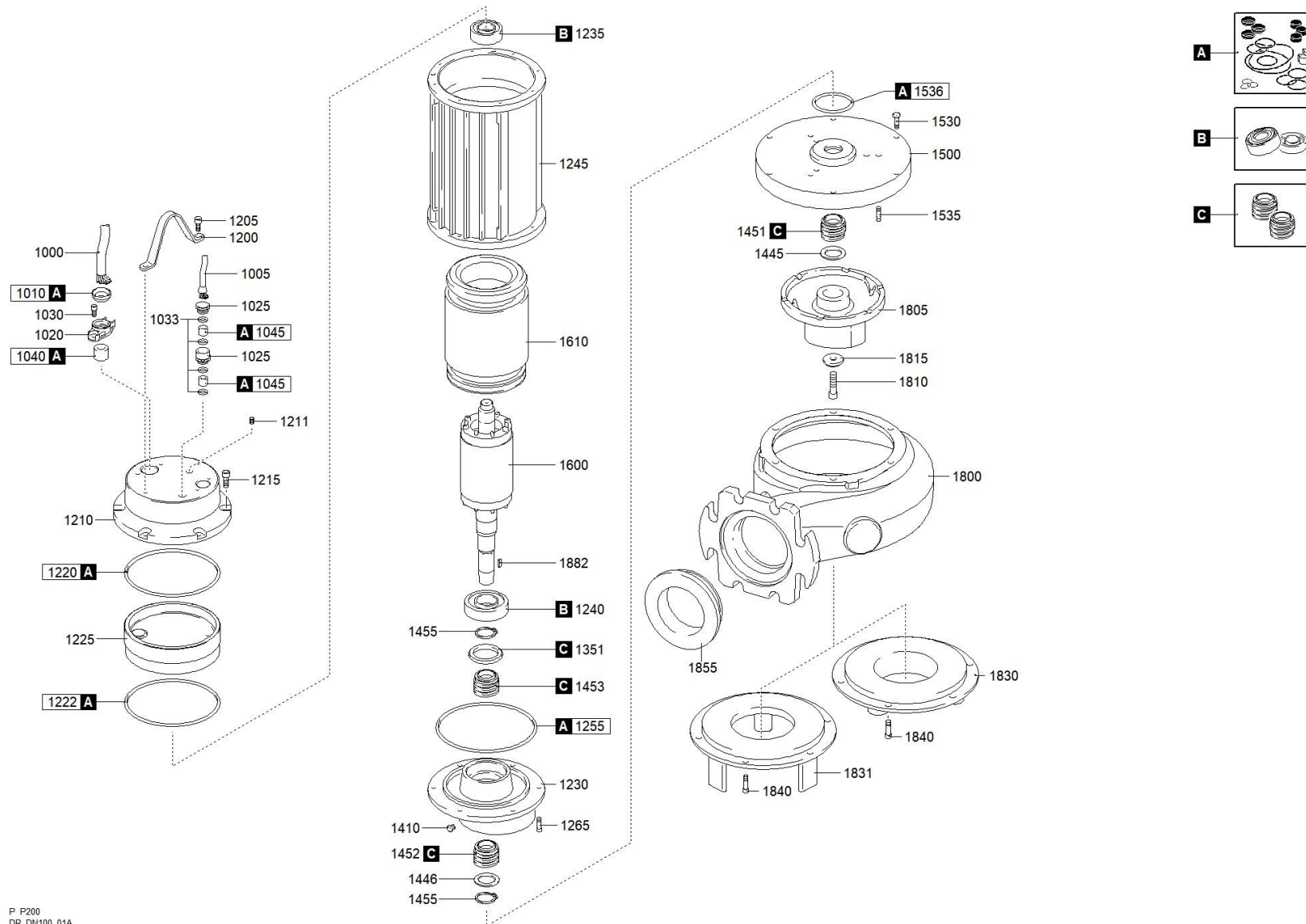

better together

0084.002 - DRP 1000/4/100 A0HT5 NGTAR8104YN00NN





better together



0084.002 - DRP 1000/4/100 A0HT5 NGTAR8104YN00NN

	Scanregn Varenummer	Description	Antal
A		GASKETS KIT	1
C	51406102134+35+36	MECHANICAL SEALS KIT	1
B		BEARINGS KIT	1
1000		CAVO POTENZA	1
1010	51406101257	RING NUT [POWER CABLE]	1
1020	51406111254	CABLE GLAND [POWER CABLE]	1
1030		SCREW - CABLE GLAND [POWER CABLE]	2
1040	51406101256	RUBBER GASKET [POWER CABLE]	1
1050		COLLAR CLAMP [POWER CABLE]	2
1200	51406101252	HANDLE	1
1205		SCREW [HANDLE >> COVER]	2
1210	51406101221	COVER	1
1211		CAP [TIGHTNESS TEST]	1
1215		SCREW [COVER >> MOTOR CASE]	6
1220	51406105518	GASKET [COVER >> UPPER BEARING HOLDER]	1
1225	51406101206	UPPER BEARING HOLDER	1
1230	51406101205	LOWER BEARING HOLDER	1
1235	51806308	UPPER BEARING	1
1240	51806308	LOWER BEARING	1
1245	51406101210	MOTOR CASE	1
1255	51406105518	GASKET [MOTOR CASE >> LOWER BEARING HOLDER]	1
1265		SCREW [LOWER BEARING HOLDER >> MOTOR CASE]	6
1410	51406055427	CAP [OIL CHAMBER]	1
1445		WASHER [1st MECHANICAL SEAL]	1
1446		WASHER [2nd MECHANICAL SEAL]	1
1451	51406102134+35+36	1st MECHANICAL SEAL	1
1452	51406102134+35+36	2nd MECHANICAL SEAL	1
1453	51406102134+35+36	3th MECHANICAL SEAL	1
1455		SEEGER [1st MECHANICAL SEAL >> 2nd MECHANICAL SEAL]	1
1500	51406064362	PUMP PLATE	1
1530		SCREW [PUMP PLATE >> PUMP BODY]	6
1535		SCREW [PUMP PLATE >> LOWER BEARING HOLDER]	6
1536	51406055545	GASKET [PUMP PLATE >> LOWER BEARING HOLDER]	1
1600	51406101202	SHAFT WITH ROTOR	1
1610	51406103400	WOUND STATOR	1
1800	51406101125	PUMP BODY	1
1805	51406101141	IMPELLER	1
1810	51406055000	LOCKING IMPELLER	1

1815		LOCKING WASHER [IMPELLER]	1
1831	51406101145	SUCTION FLANGE WITH FOOT	1
1840		SCREW [SUCTION FLANGE >> PUMP BODY]	6
1855	51406101450	DISCHARGE GASKET	1
1882	51406105452	KEY [IMPELLER]	1