

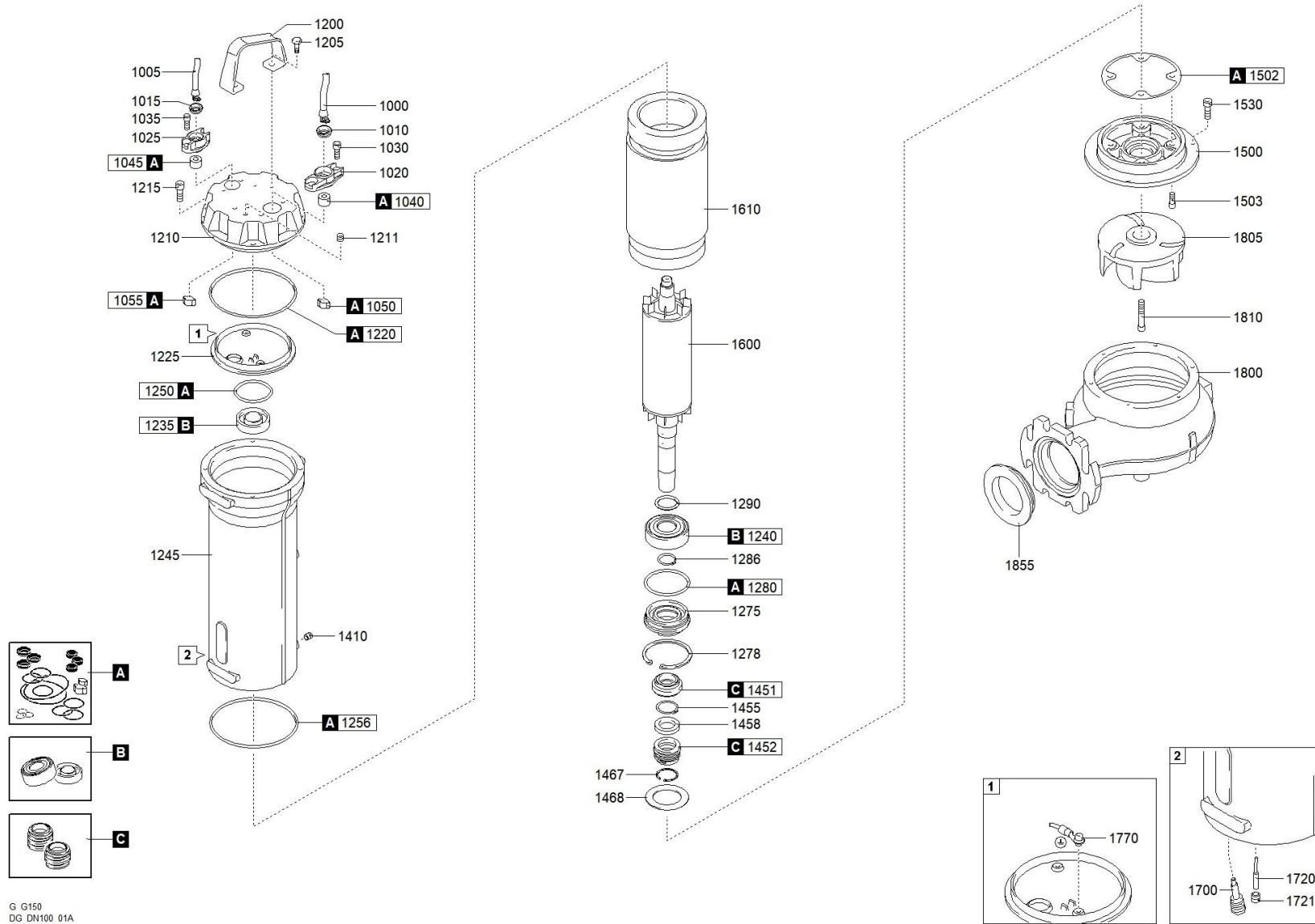

better together

1515.002 - DGG 750/4/100 G0FT5 NGTSB51040S00NN





better together



1515.002 - DGG 750/4/100 G0FT5 NGTSB51040S00NN

	☰	↕	Varenummer Scanregn	↕	Description	Antal
A			51414330A		GASKETS KIT	1
C			51414330C		MECHANICAL SEALS KIT	1
B					BEARINGS KIT	1
1000					CAVO POTENZA	1
1010					RING NUT [POWER CABLE]	1
1020					CABLE GLAND [POWER CABLE]	1
1030					SCREW - CABLE GLAND [POWER CABLE]	2
1040					RUBBER GASKET [POWER CABLE]	1
1050					COLLAR CLAMP [POWER CABLE]	1
1200					HANDLE	1
1205					SCREW [HANDLE >> COVER]	2
1210					COVER	1
1211					CAP [TIGHTNESS TEST]	1
1211					CAP [TIGHTNESS TEST]	1
1215					SCREW [COVER >> MOTOR CASE]	6
1220					GASKET [COVER >> UPPER BEARING HOLDER]	1
1225					UPPER BEARING HOLDER	1
1235			518063052Z		UPPER BEARING	1
1240			518063072ZC3		LOWER BEARING	1
1245					MOTOR CASE	1
1250					GASKET [UPPER BEARING]	1
1256					GASKET [MOTOR CASE >> PUMP PLATE]	1
1275					LOWER BEARING FLANGE	1
1278					SEEGER [LOWER BEARING FLANGE]	1
1280					GASKET [LOWER BEARING FLANGE]	1
1286					SEEGER [LOWER BEARING >> LOWER BEARING FLANGE]	1
1290					DISTANCE RING [LOWER BEARING]	1
1410					CAP [OIL CHAMBER]	1
1410					CAP [OIL CHAMBER]	1
1451					1st MECHANICAL SEAL	1
1452					2nd MECHANICAL SEAL	1
1455					SEEGER [1st MECHANICAL SEAL >> 2nd MECHANICAL SEAL]	1
1458					DISTANCE RING [1st MECHANICAL SEAL >> 2nd MECHANICAL SEAL]	1
1467					SEEGER [2nd MECHANICAL SEAL]	1
1468					DISTANCE RING [2nd MECHANICAL SEAL]	1
1500					PUMP PLATE	1
1502					GASKET [PUMP PLATE]	1
1503					SCREW [PUMP PLATE >> MOTOR CASE]	6

1520	GASKET [PUMP PLATE >> PUMP BODY]	1
1530	SCREW [PUMP PLATE >> PUMP BODY]	6
1600	SHAFT WITH ROTOR	1
1610	WOUND STATOR	1
1700	HUMIDITY PROBE [OIL CHAMBER]	1
1800	PUMP BODY	1
1805	IMPELLER	1
1810	LOCKING IMPELLER	1
1855	DISCHARGE GASKET	1